

**Rollei**

# Stativ | Tripod Compact Traveler Star S3 Plus



## **Bedienungsanleitung User Guide**

For German | English | French | Spanish  
Italian | Portuguese | Chinese  
(simplified and traditional)

[www.rollei.de](http://www.rollei.de)

Bedienungsanleitung . . . . .	3
Manual instruction . . . . .	4
Notice d'utilisation . . . . .	5
Instrucciones . . . . .	6
Istruzioni . . . . .	7
Instruções . . . . .	8
使用説明 . . . . .	9
使用说明 . . . . .	10



Stativ | Tripod

# Compact Traveler Star S3 Plus

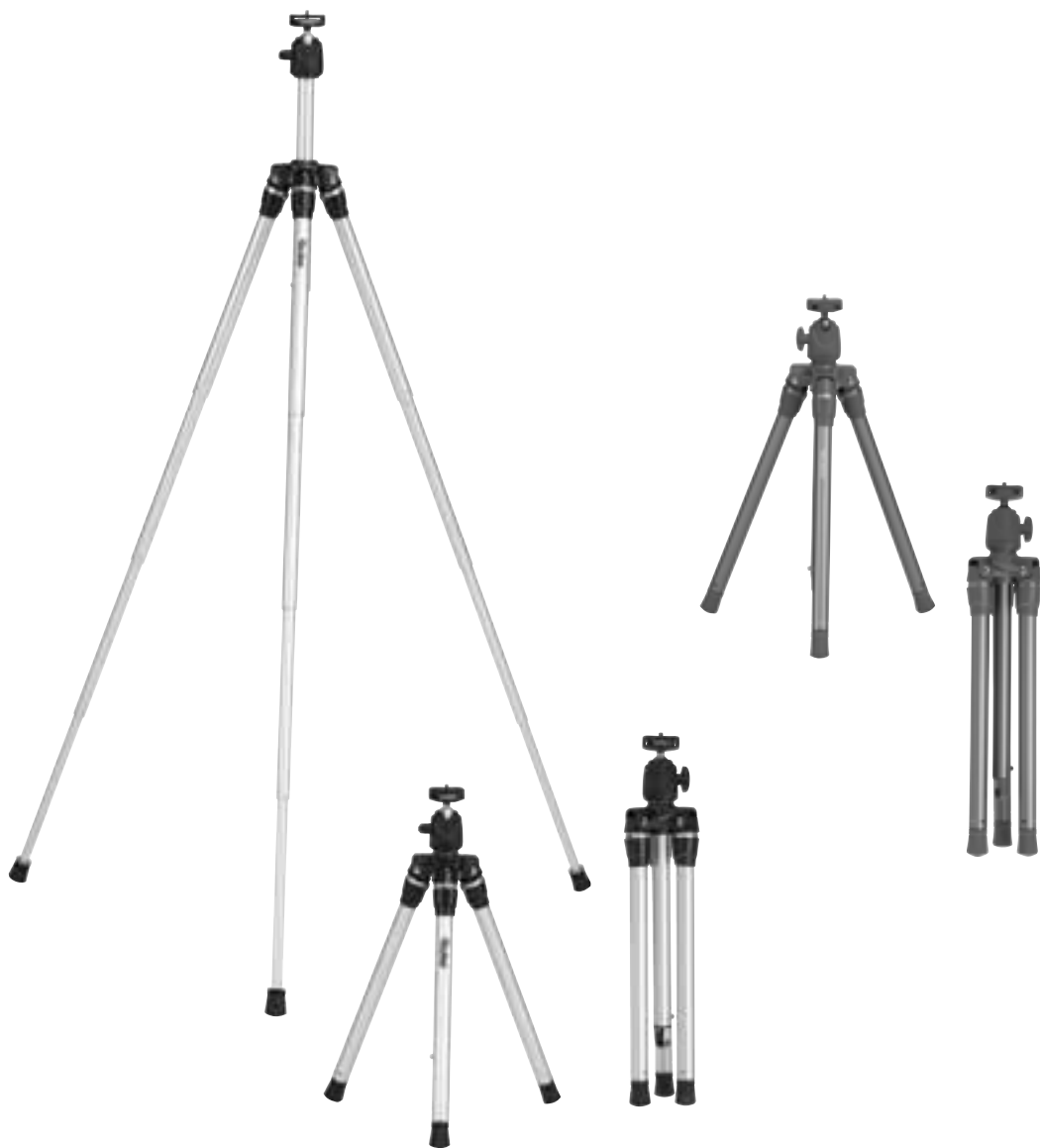

# Rollei Compact Traveler Star S3 Plus Bedienungsanleitung

Vielen Dank, dass Sie unser Rollel Produkt gewählt haben. Vor dem Gebrauch bitte sorgfältig lesen.

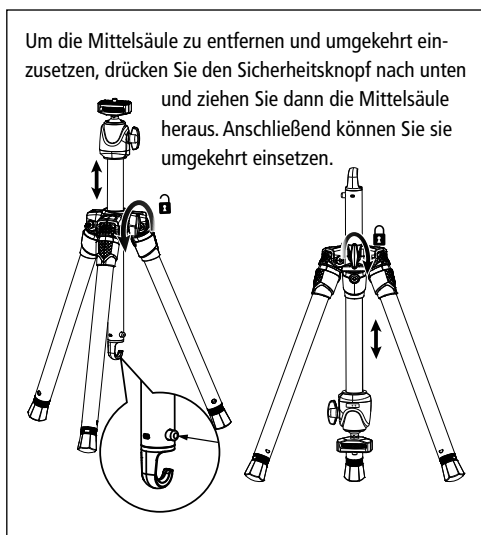
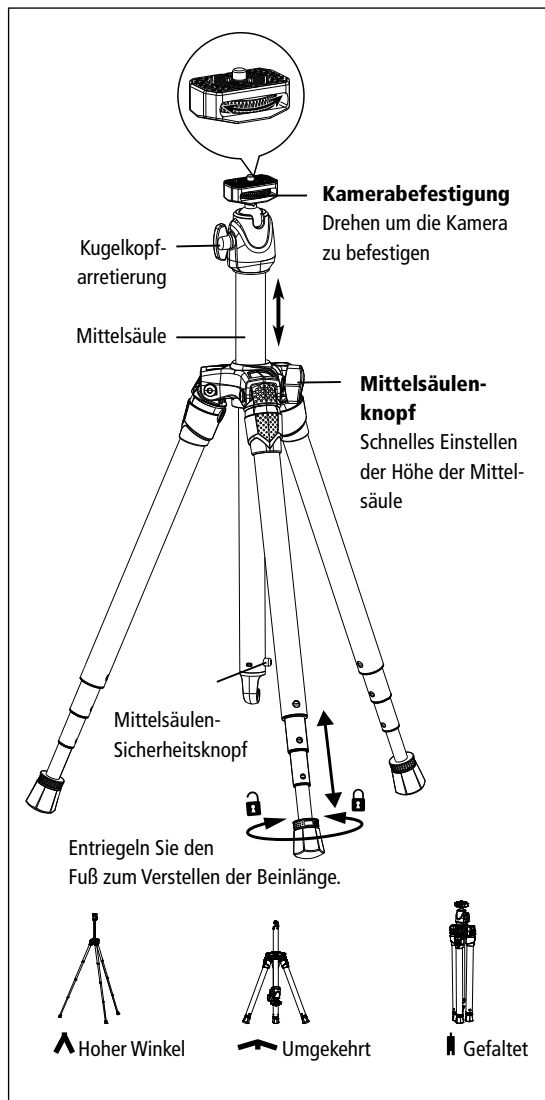

**Extra:** Inbusschlüssel (zum Lösen oder Befestigen der Beine)

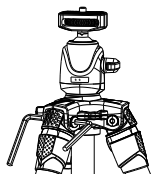

Segmente  
4



Max. D  
22 mm



Geklappt  
435 mm



Min. H  
420 mm



Max. H  
1270 mm



Gewicht  
732 g



Tragkraft  
2,5 kg

Änderungen von Design und technischen Daten bleiben vorbehalten und bedürfen keiner Ankündigung.

# Rollei Compact Traveler Star S3 Plus Manual

Thanks for choosing this Rollei product. Please read this user guide carefully before using this product.

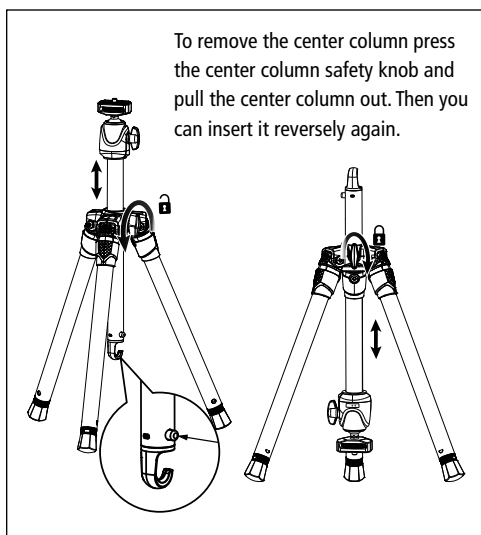
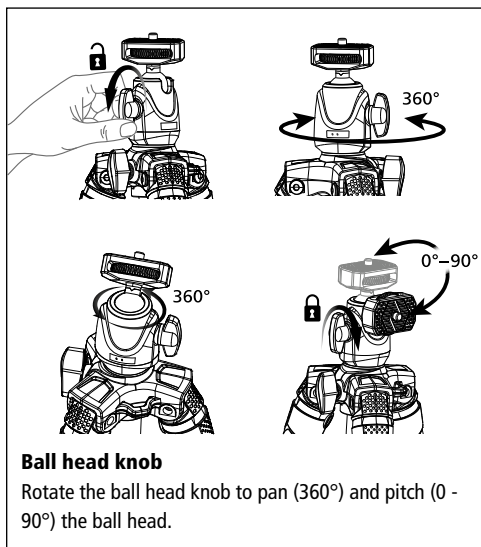
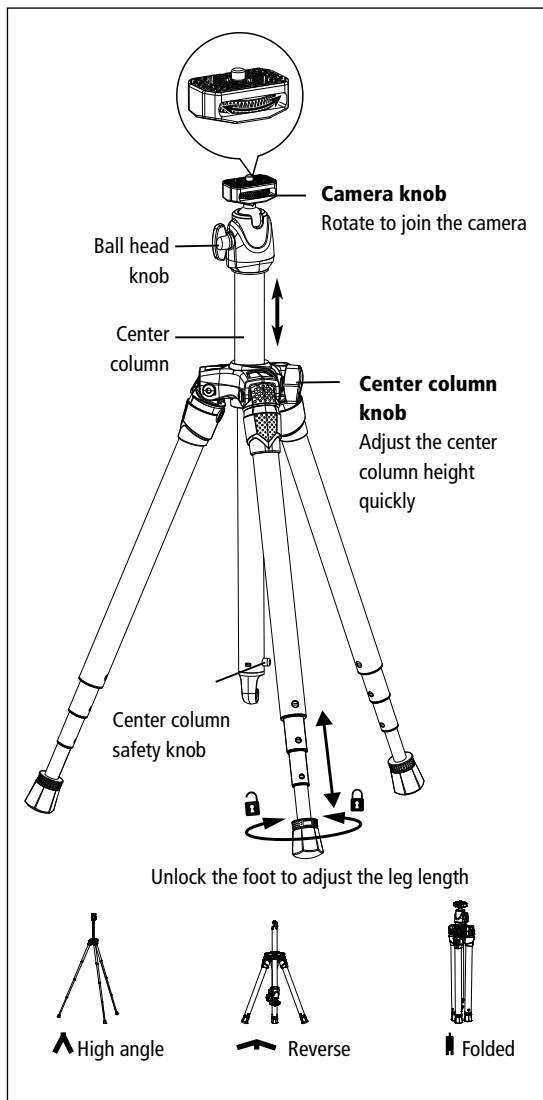

**Extra:** Hexagon wrench  
(to loosen or tighten the legs)

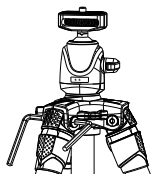

Sections  
4



Max. Ø  
22 mm



Folded  
435 mm



Min. Height  
420 mm



Max. Height  
1270 mm



Weight  
732 g



Load  
2.5 kg

\*Any change in design, specification and parameter are subject to real product.

# Rollei Compact Traveler Star S3 Plus Notice d'utilisation

Merci d'avoir choisi nos produits. A lire attentivement avant l'utilisation.

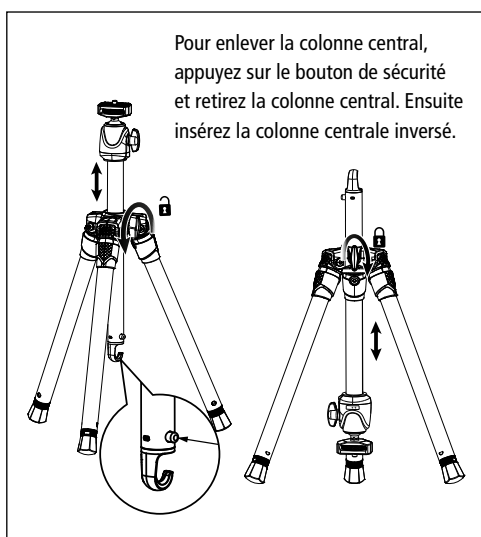
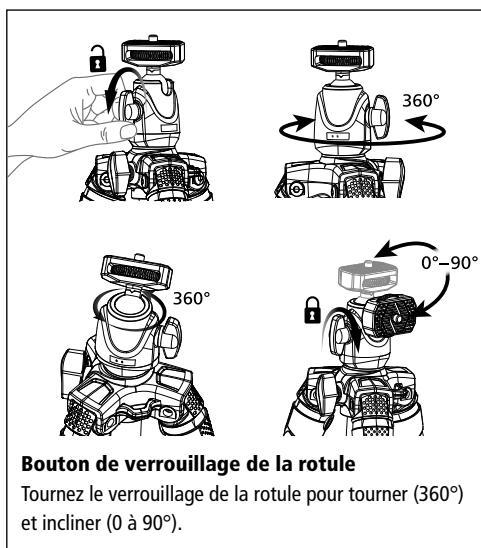
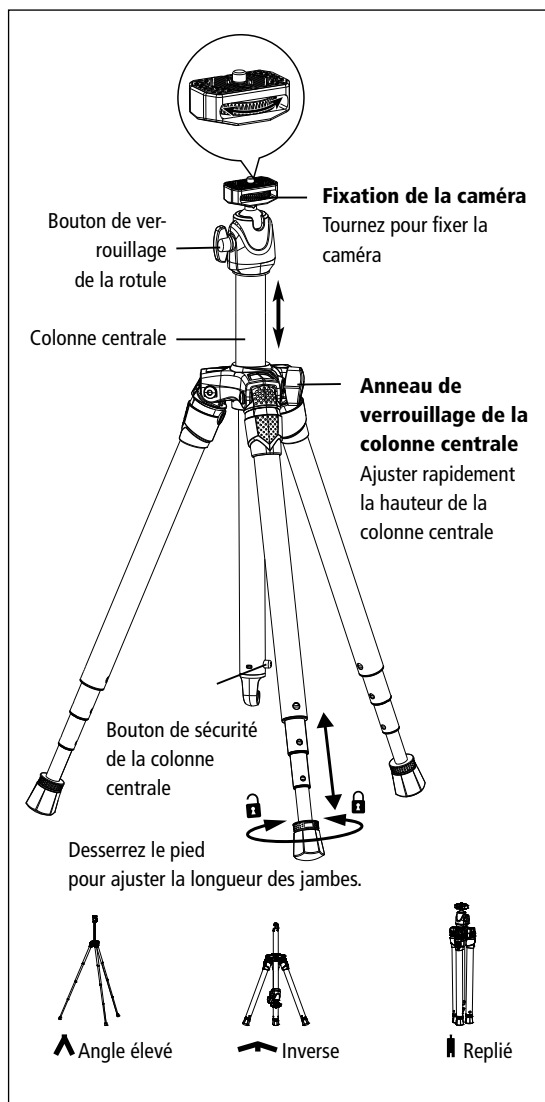

**Option:** Clé allen (pour résoudre ou resserrer les jambes)

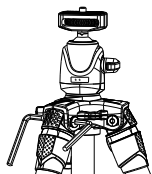

Segment  
4



Max. Ø  
22 mm



Replié  
435 mm



Min. H  
420 mm



Max. H  
1270 mm



Poids  
732 g



Capacité  
2,5 kg

\*Nous nous réservons le droit de modifier les données du design et techniques sans préavis.

# Rollei Compact Traveler Star S3 Plus Manual

Gracias por elegir este producto Rollei. Por favor lea esta guía de usuario antes de usar este producto.

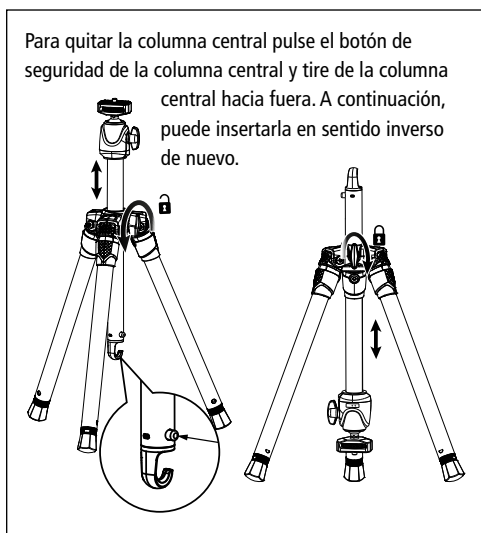
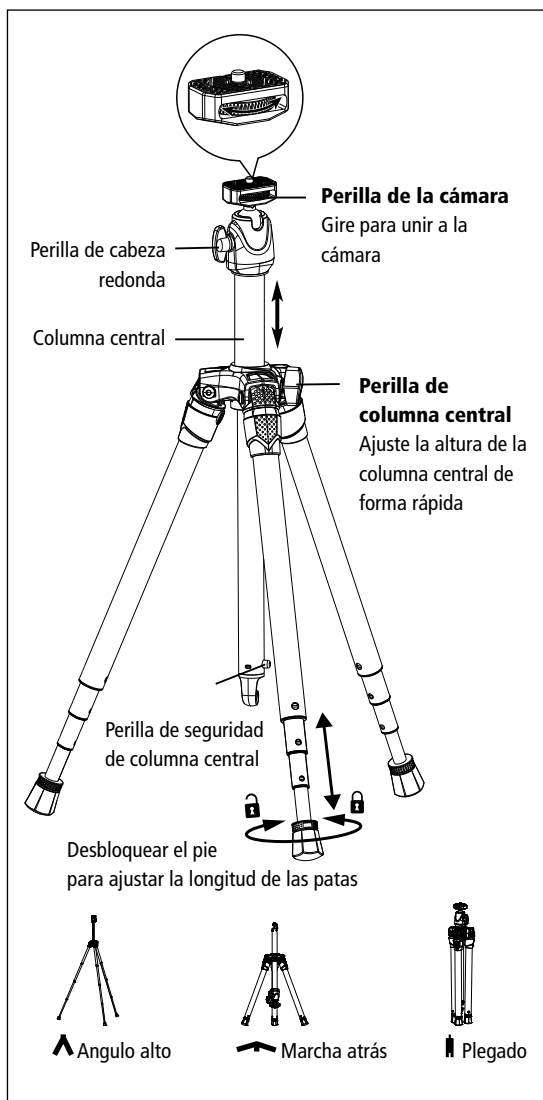

**Extra:** llave hexagonal (para aflojar o apretar las patas)

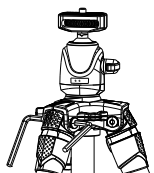

Secciones  
4



D. máx.  
22 mm



Plegado  
435 mm



A. mín.  
420 mm



A. máx.  
1270 mm



Peso  
732 g



Carga  
2,5 kg

\*Cualquier cambio en el diseño, las especificaciones y los parámetros están sujetos al producto real.

## Rollei Compact Traveler Star S3 Plus Manuale

Grazie per aver scelto di acquistare questo prodotto Rollei. Leggere questa guida utente con attenzione prima di utilizzare questo prodotto.

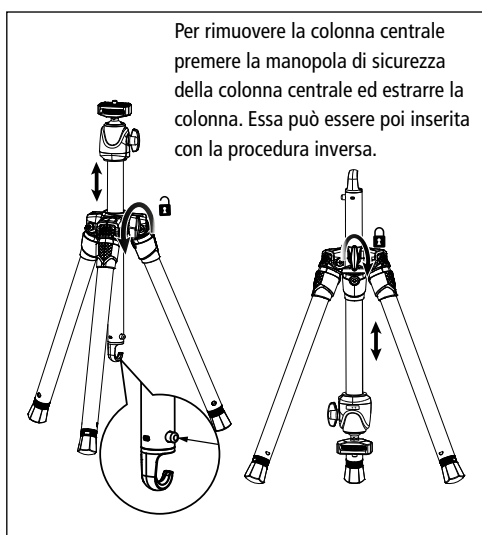
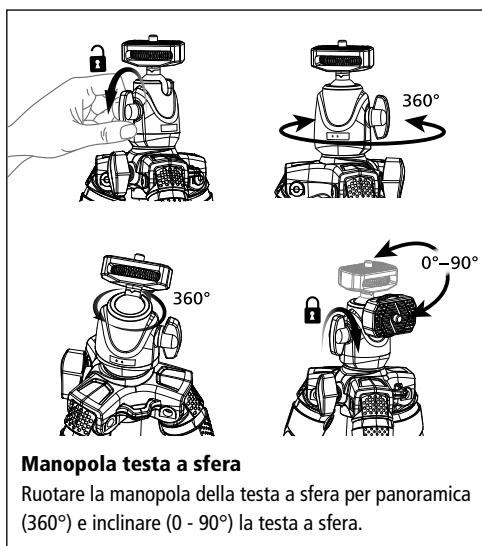
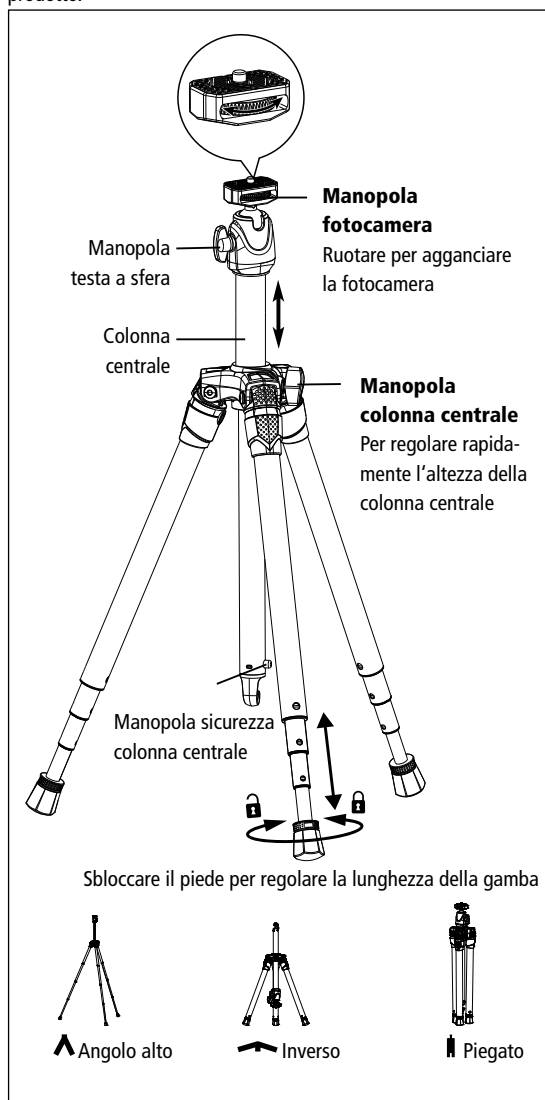

**Extra:** Chiave esagonale (per allentare o stringere le gambe)

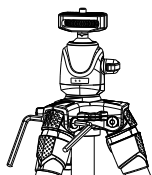

Sezioni  
4



D max.  
22 mm



Piegato  
435 mm



A min.  
420 mm



A max.  
1270 mm



Peso  
732 g



Portata  
2.5 kg

\*Qualsiasi modifica a design, specifiche e parametri è soggetta al prodotto reale.



# Rollei Compact Traveler Star S3 Plus Manual

Obrigado por escolher este produto Rollei. Por favor, leia cuidadosamente este guia do utilizador antes de usar este produto.

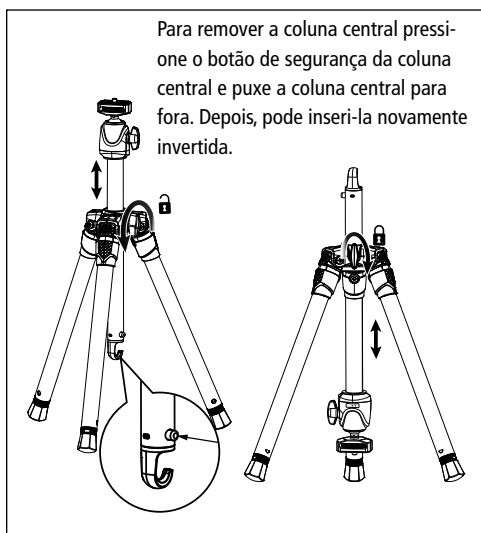
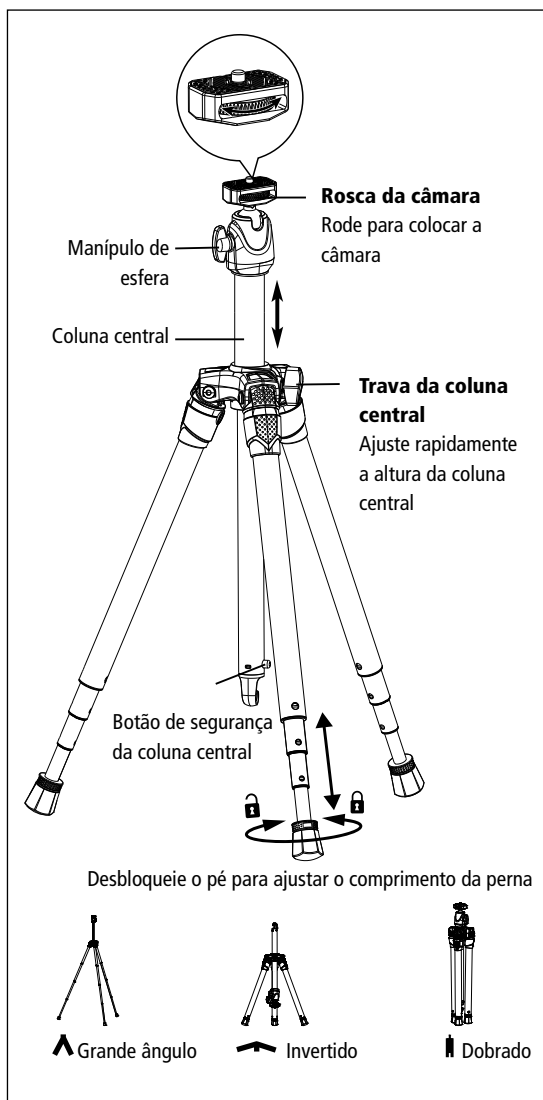

**Extra:** Chave hexagonal (para soltar ou fixar as pernas)

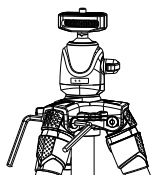

Secções  
4



D máx.  
22 mm



Dobrado  
435 mm



H mín.  
420 mm



H máx.  
1270 mm



Peso  
732 g



Carga  
2.5 kg

\*Quaisquer alterações no design, especificações e parâmetros estão sujeitas ao produto real.

# Rollei Compact Traveler Star S3 Plus 用戶手冊

感謝您選擇本款Rollei產品。使用本產品前，請仔細閱讀此用戶指南。

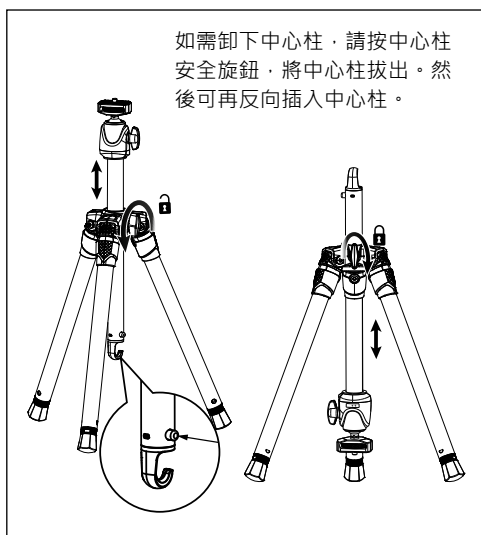
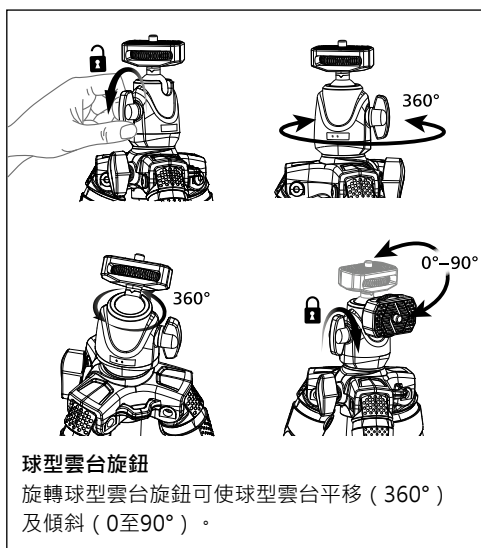
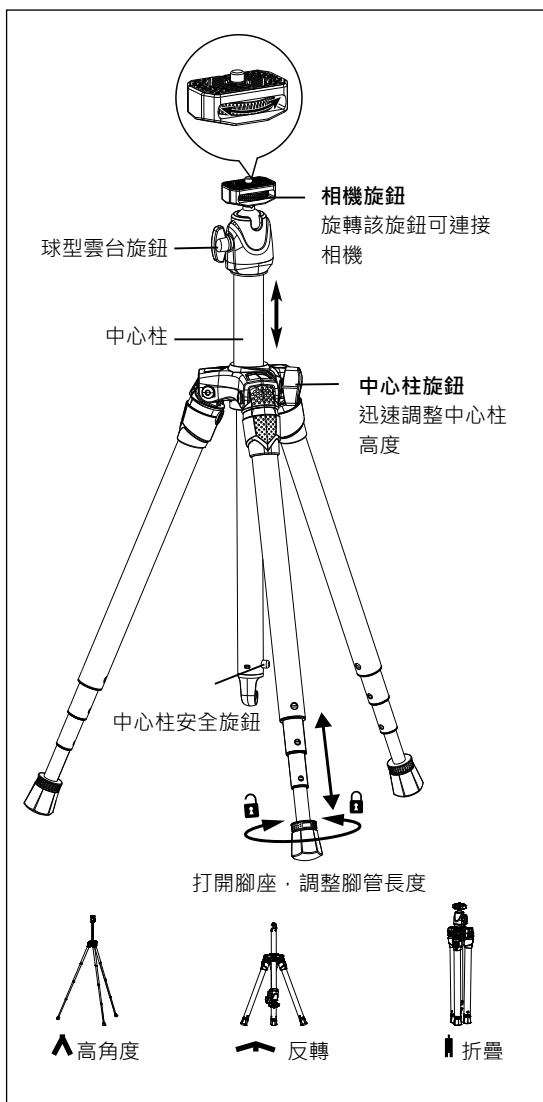

額外附件：六角扳手（鬆動或擰緊腳管）

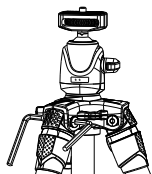

腳管節數  
4



最大直徑  
22 mm



折疊後  
435 mm



最小高度  
420 mm



最大高度  
1270 mm



重量  
732 g



承重  
2.5 kg

\*設計、規格和參數的任何變動均以實際產品為準。

# Rollei Compact Traveler Star S3 Plus 用户手册

感谢您选择本款Rollei产品。使用本产品前，请仔细阅读此用户指南。

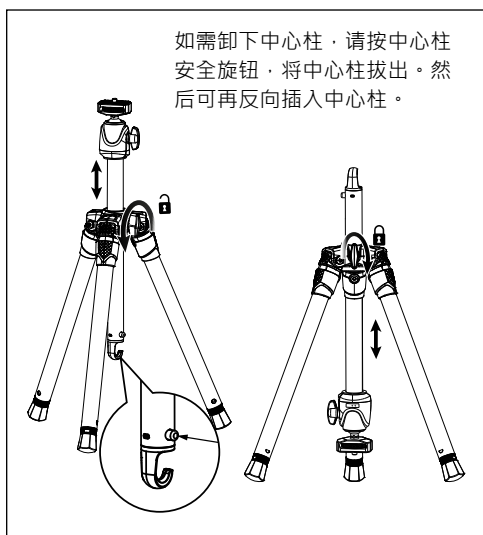
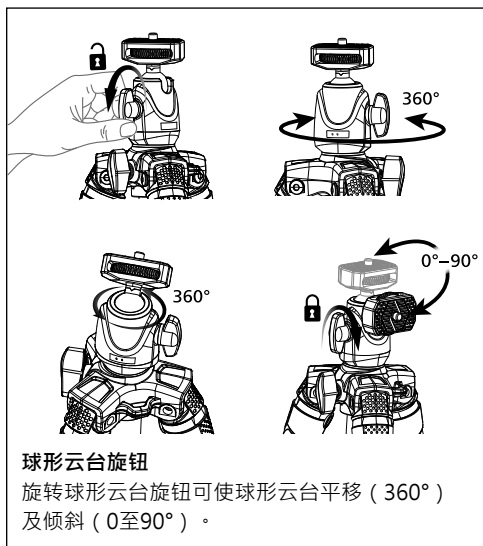
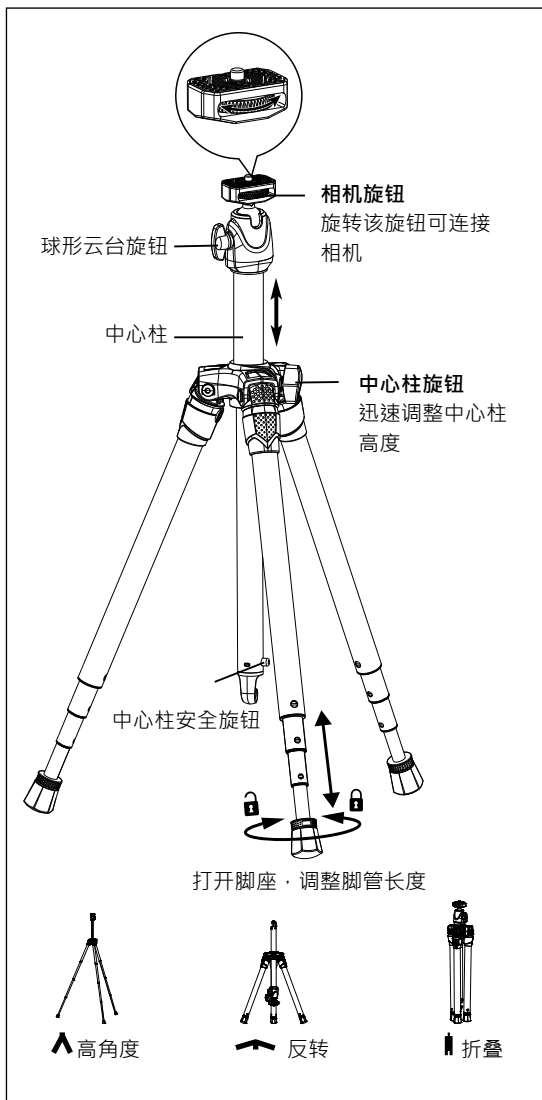

额外附件：六角扳手（松动或拧紧脚管）

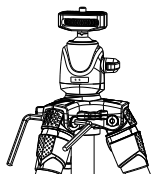

脚管分段  
4



最大直径  
22 mm



折叠后  
435 mm



最小高度  
420 mm



最大高度  
1270 mm



重量  
732 g



承重  
2.5 kg

\*设计、规格和参数的任何变动均以实际产品为准。

## For Europe

**Distribution** Rollei GmbH & Co. KG  
In de Tarpen 42, D-22848 Norderstedt

**Service Hotline** +49 40 270750270

**Return Service:** Rollei Service Deutschland  
Denisstraße 28a, D-67663 Kaiserslautern



[www.rollei.de/social](http://www.rollei.de/social)

[www.rollei.com/social](http://www.rollei.com/social)

## For Asia

分銷: Rollei HK Limited  
香港九龍觀塘成業街 7 號  
寧晉中心 17/F D2

Tel +852 2377 9023

Fax +852 2366 8091

Email [info-hk@rollei.com](mailto:info-hk@rollei.com)

分銷: Rollei HK Limited

香港九龍觀塘成業街 7 號

寧晉中心 17/F D2

Tel +852 2377 9023

Fax +852 2366 8091

Email [info-hk@rollei.com](mailto:info-hk@rollei.com)



[www.cn.rollei.com/social](http://www.cn.rollei.com/social)